

CSI Bolt-On Heating Systems

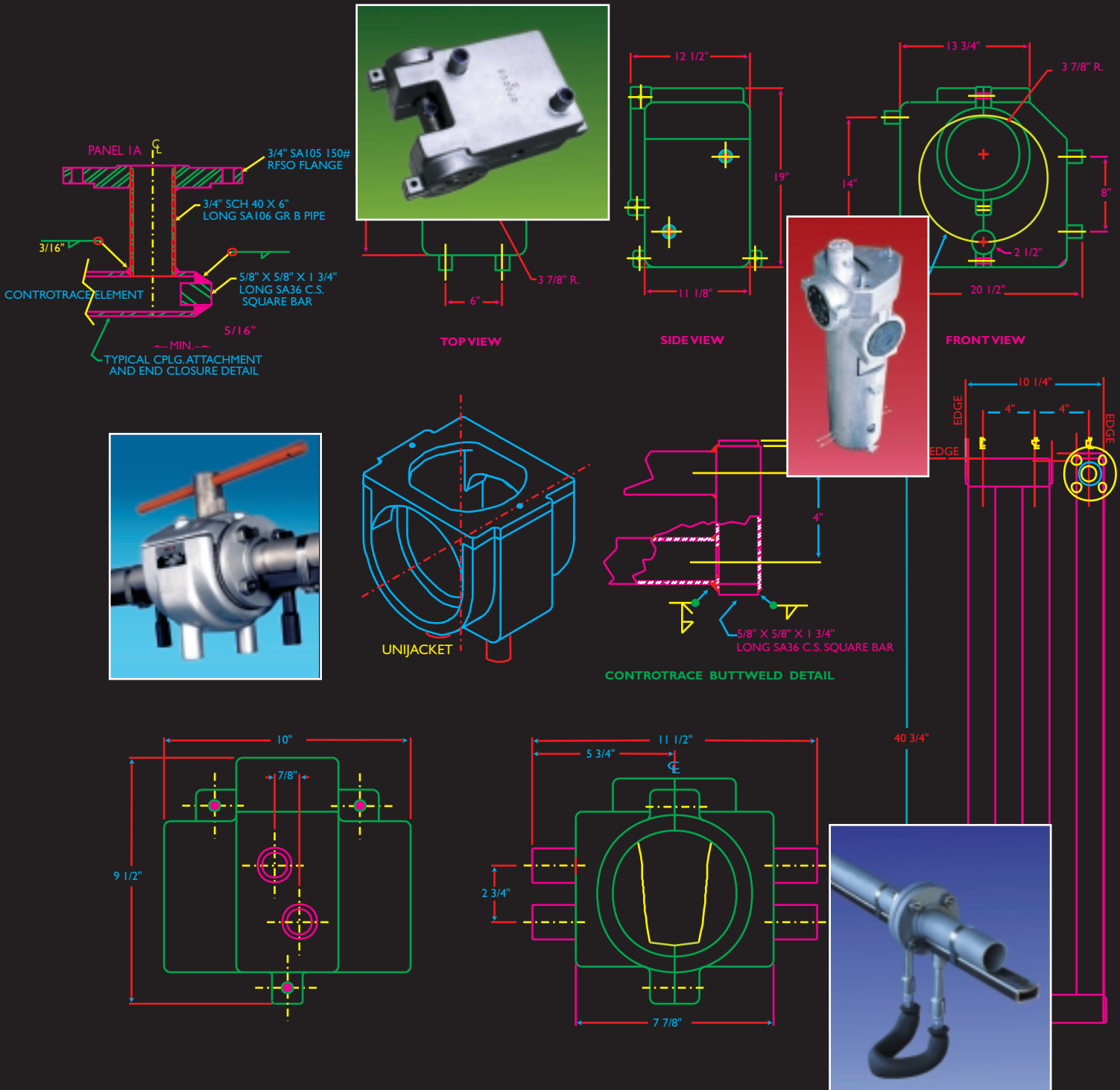

Piping • Valves • Pumps • Meters • Instruments • Tanks • Vessels

The CSI Bolt-On Heating System

Integrally jacketed piping systems and components have long been the preferred method used with processes that require elevated temperatures for efficient in-plant transfer of products such as sulfur, bitumens, phthalic anhydride, DMT and polymers. Pumpability, product quality, flow properties and reliable equipment operation for many of these processes depend on viscosity ranges controlled by temperature.

Integral jacketing offer the advantages of unit construction, high rates of heat transfer from the heating medium to the process, and the ability to maintain processing temperatures within close tolerances.

The disadvantages of integrally jacketed systems are the limited selections available for jacketed components, relatively long deliveries for these components, and inconsistencies of quality of the jacketed components due to the lack of industry-wide fabrication standards.

The CSI Bolt-On Heating System is comprised of products that respond positively

to the disadvantages cited for integral jacketing. The bolt-on system provides thermal performance necessary to meet narrow-envelope processing. The product heating options are

versatile, ranging from the primary function of temperature maintenance to more thermally complex applications of heat-up and melt-out, and, infrequently, heat exchanger duty of process heating or cooling.

The CSI Bolt-On Heating System consists of two basic product groups which are discussed in more detail on subsequent pages:

- **ControHeat Bolt-On Jackets** for valves, pumps, meters and other components.
- **ControTrace Heating Elements** for piping, tanks and vessels.

This brochure outlines the products and services offered by CSI to help designers and engineers optimize performance and value for specific bolt-on heating systems.



Benefits of the CSI Bolt-On Heating System

There are several benefits that accompany the CSI Bolt-On Heating System. The major ones are:

Component Selection Versatility.

Because components of the system most often are line-size components, project engineers can select from a very broad range of standard products. The base component, of

course, must be able to operate at elevated design temperatures. More than 3500 typical processing components are represented in the ControHeat Jacket pattern inventory. Several new patterns are added to this inventory each week.

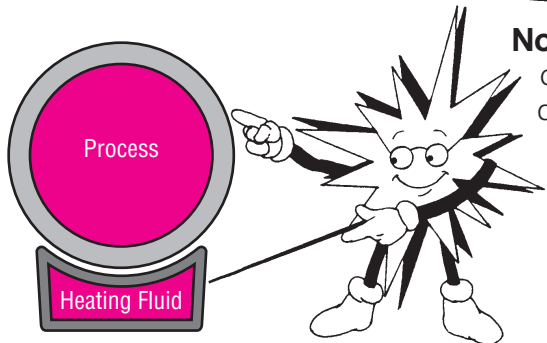
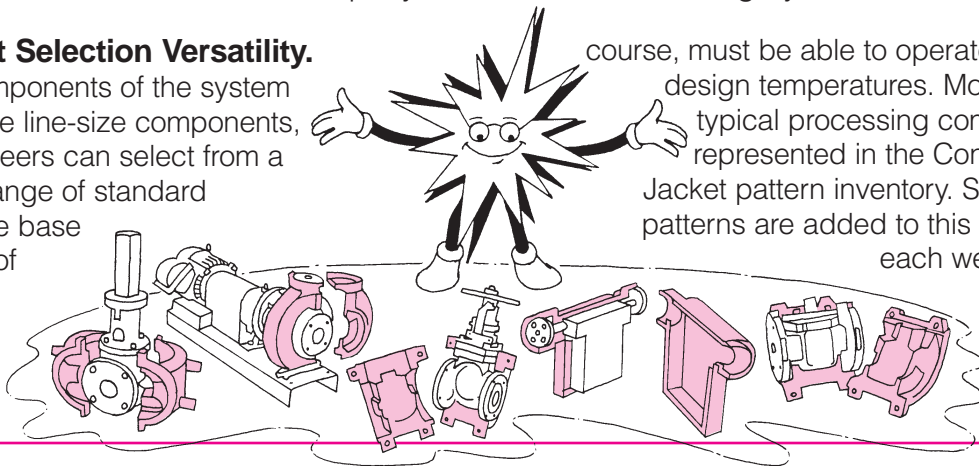

No Cross-Contamination.

Defects in castings or cracks in core piping cause cross-contamination. The double-wall design of the bolt-on heating system eliminates the possibility of cross-contamination. The heating fluid can't reach the process, and the process can't flood the heating system.

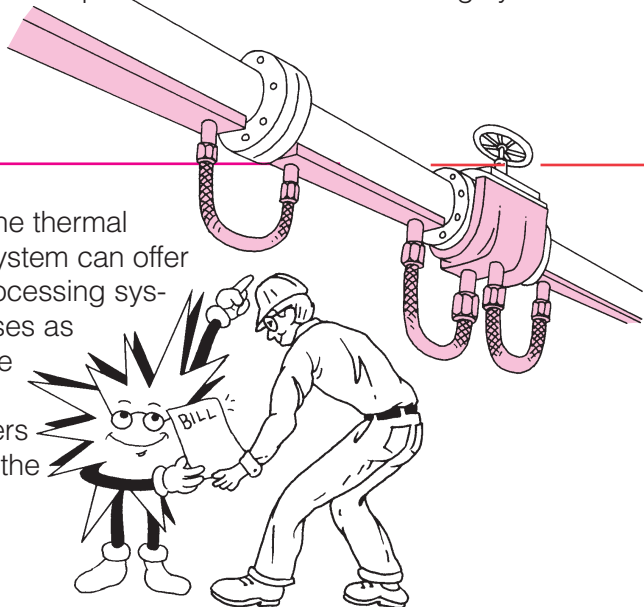

Economical Temperature Control.

Depending on the thermal requirements of the process, the CSI Bolt-On Heating System can offer significant cost savings compared to a fully jacketed processing system. In general, the cost of the clamp-on system increases as the required temperature of the process approaches the temperature of the heating fluid. When the design temperature envelope is very narrow, say 2-4°F, designers must carefully analyze potential chill spots to determine the optimum heat coverage.

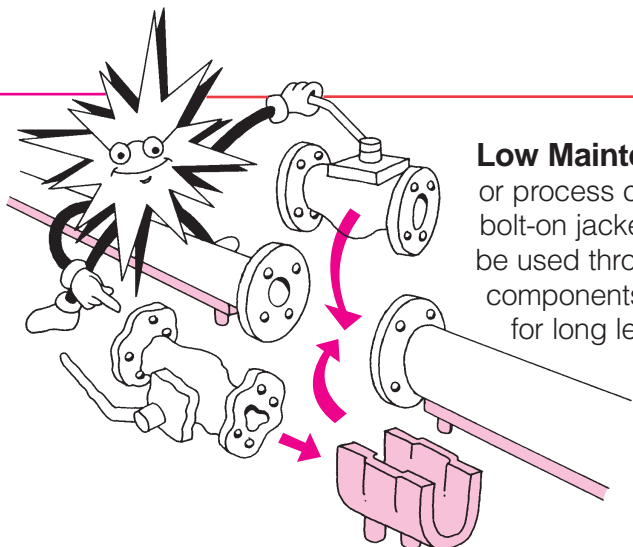

Low Maintenance Costs.

Practically any piece of equipment or process component can be economically heated with a bolt-on jacket. Because standard line-size components can be used throughout the system, the replacement of individual components like a valve can be made without concerns for long lead times and "crises" expediting.

ControHeat Jackets Cover Valves

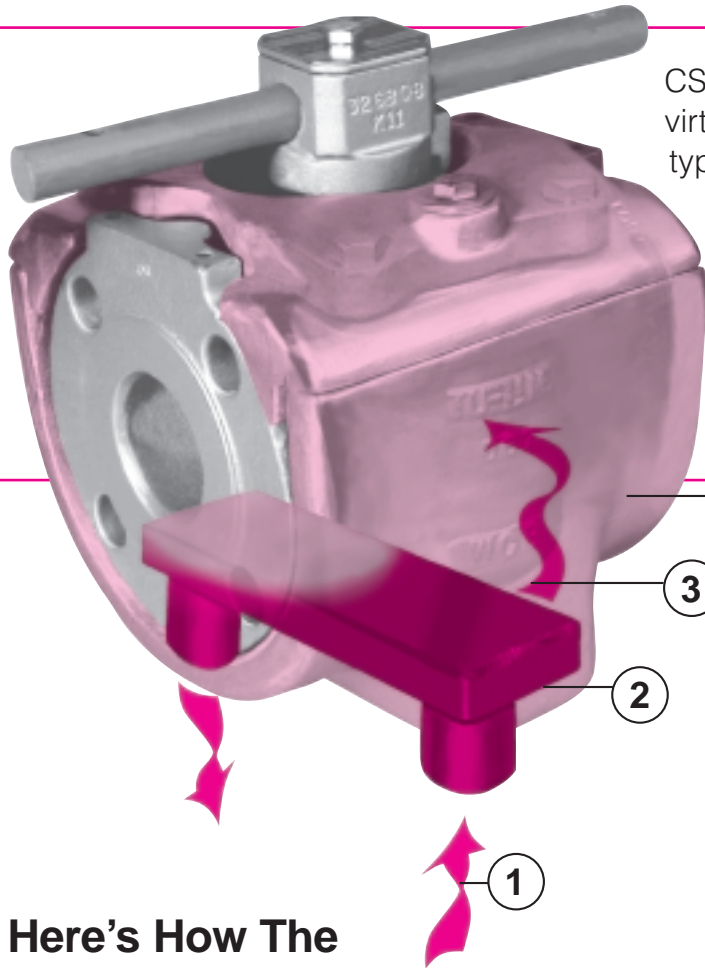

CSI makes ControHeat Bolt-On Jackets for virtually any valve. Generally, there are two types of jacket construction offered: One-piece jackets, called UniJackets, for valves sizes 3-inch and smaller; and two-piece jackets for valves sizes 4-inch and larger. Very large valves like 20-inch gate valves may utilize more than two pieces to accommodate ease of installation.

Here's How The ControHeat Jacket Works:

1. Pressurized heating fluid enters the pressure chamber embedded in the aluminum casting. The pressure chamber may be either carbon steel or stainless steel.
2. The pressure chamber is designed, manufactured and tested in accordance with the ASME Boiler and Pressure Vessel Code, Sec. VIII, Div. 1.
3. The aluminum casting, which never contacts the pressurized heating fluid, rapidly transfers heat from the pressure chamber to the external surface of the valve.
4. Normally, heat transfer cement is used with the jacket to minimize any air gap between the casting and the valve body. The cement promotes efficient heat transfer.

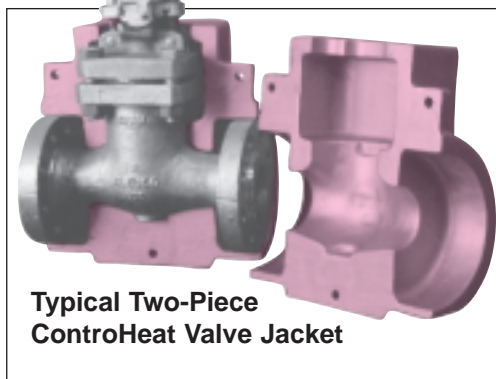
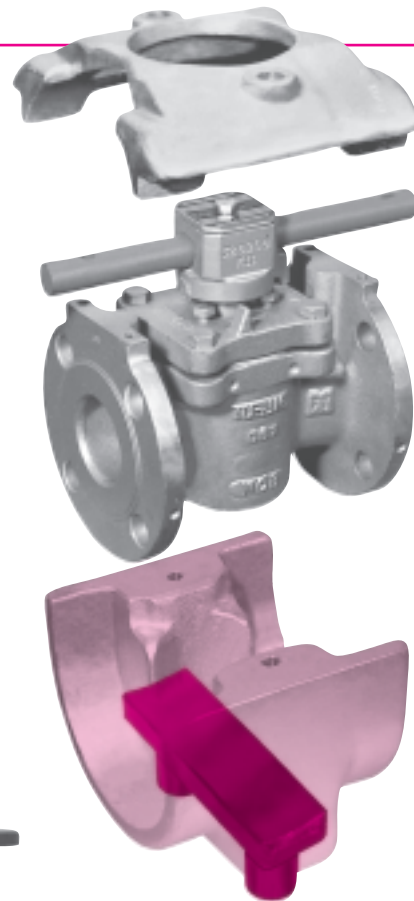

Typical Two-Piece ControHeat Valve Jacket

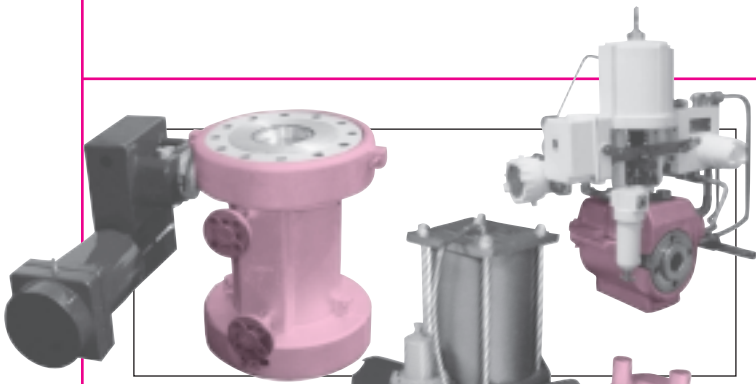

Control valves with integral jackets often require very long lead times for deliveries. Sometimes the long delivery times force instrument engineers to sacrifice performance for availability. ControHeat Jackets allow you to select the optimum valve for the process without concern for the jacket.



Designed for hot-oil vapor service, this two-piece ControHeat jacket with flanged connections and extended coverage for mating flanges is used in 650°F service on a 20-inch ball valve in a polymer reactor operation.

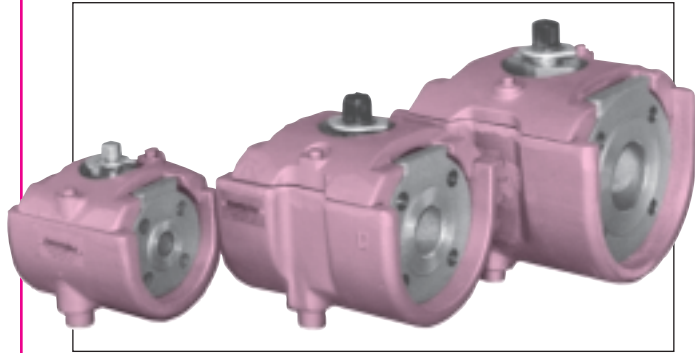

Any ControHeat Valve Jacket can be designed to heat mating pipe flanges as shown on these plug valve jackets used in BPA service.

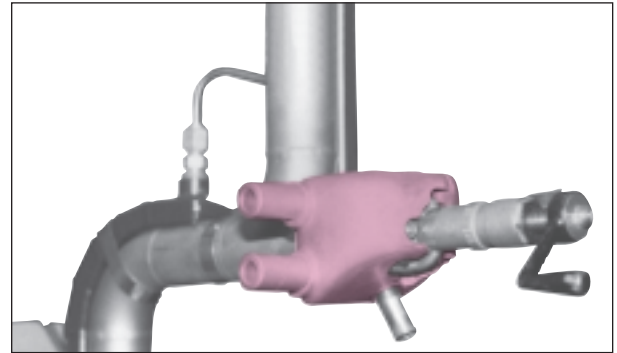

This UniJacket on an off-the-shelf sampling valve keeps the valve plug-free, ready to operate at all times.

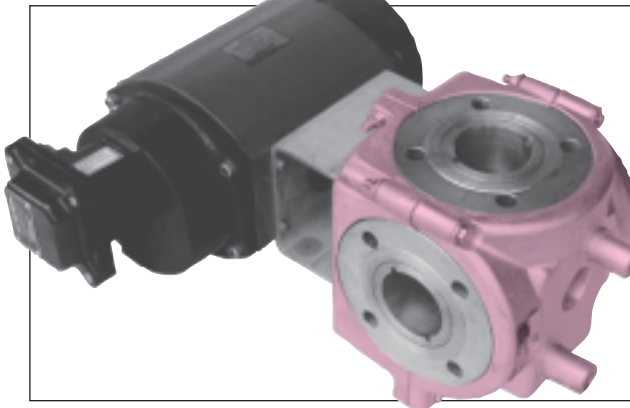

Three-way ball valves are easily heated with ControHeat Jackets. Various styles of actuator brackets can be accommodated.

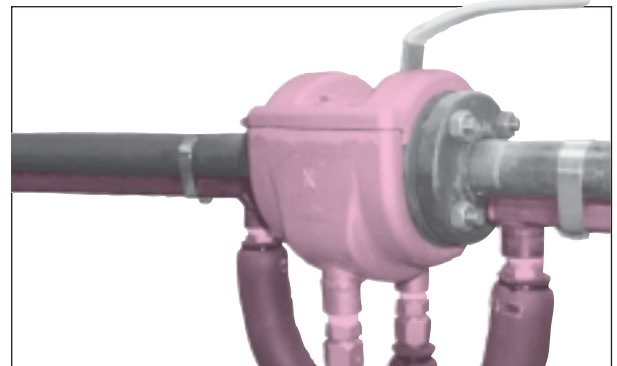

UniJacket installed on ball valve. CSI insulated flexible jumpovers connect the jacket to ControTrace Elements heating adjacent piping.

ControHeat Jackets for Pumps

ControHeat Bolt-On Jackets are widely used throughout the processing industry to improve pump efficiencies, prevent motor burnout and promote uniform processing temperatures. Some critical metering pump applications require jacketing to assure accurate throughput. Certain gear pump applications require jacketing to minimize degradation of polymers and other products that are shear sensitive. The barrels of progressive cavity pumps may need to be

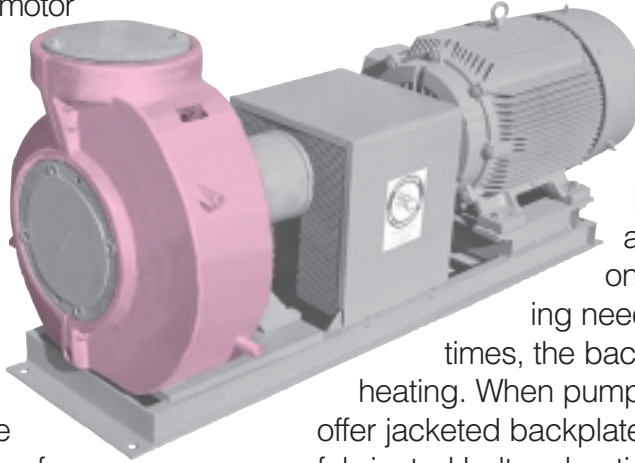

heated for foodstuffs such as chocolate, syrups and dairy products. In some batch-type operations, pump jacketing may be needed during start-up only. In pumping applications like sulfur, phthalic anhydride, or DMT, not only does the pump casing need to be heated at all times, the backplate also may need heating. When pump manufacturers do not offer jacketed backplates, CSI offers both fabricated bolt-on heating jackets as well as ControHeat Jackets.

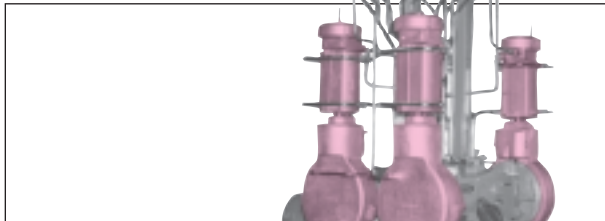

Two Metering Diaphragm Pumps with ControHeat Jackets. The jackets cover four pump heads as well as check valve assemblies.

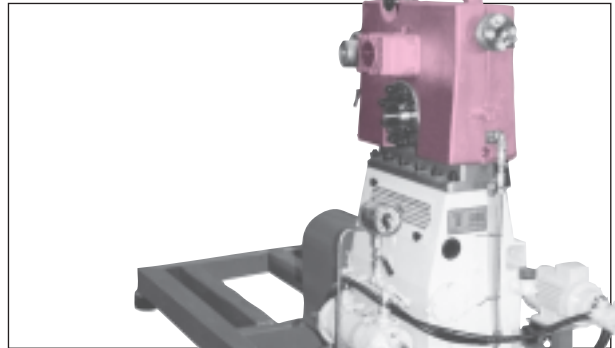

High-Pressure Piston Pump with 3-phase electric ControHeat Jacket.

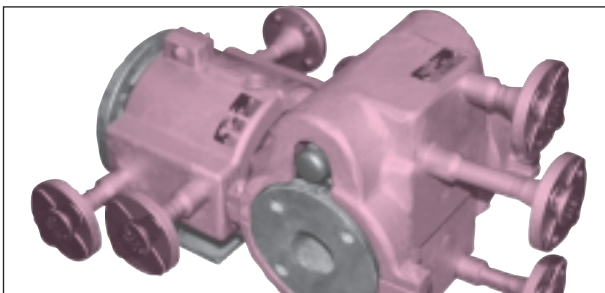

Gear Pump with Mag Drive and External Relief Valve totally jacketed for hot-oil application. ControHeat Jacket on mag drive used for heating.

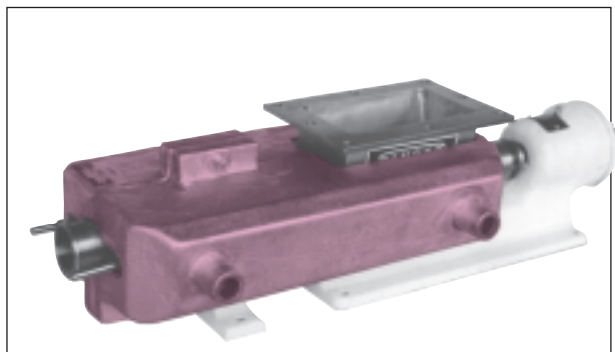

Progressive Cavity Pump for use in CIP service for foodstuffs.

ControHeat Jackets for Meters & Instruments

Accurate process data and process performance often depend on instruments, meters and safety devices operating at elevated process temperatures. CSI makes jackets for many types of meters, instruments and related equipment: DP cells, vortex shedding meters, rupture discs, coriolis flow meters, viscometers, tank vents, level indicators

and chemical tees. Few of these components are available with integral jackets. The ControHeat Jacket has a history of successful service with these components. In fact, several manufacturers of these products have standardized on the ControHeat Jacket to complement their product lines.

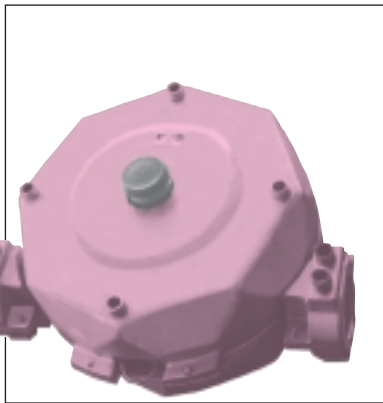
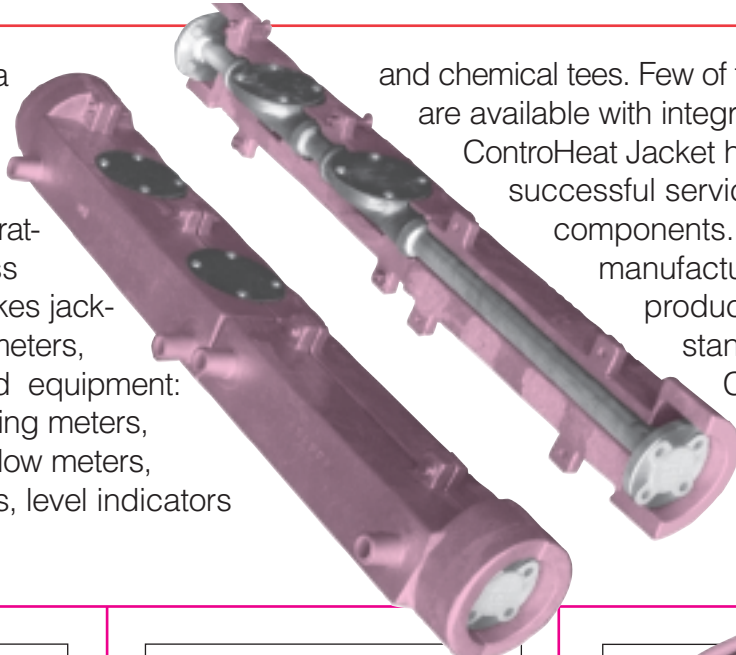

Coriolis Meter used in high temperature service of pre-polymer process. Jacket is hot-oil heated and maintains meter at 600° F.

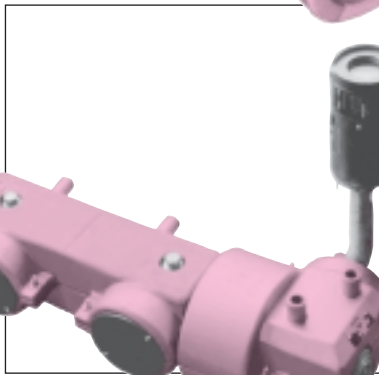

Liquid Level Indicator used in palm oil storage application. Jacket completely covers all process-wetted surfaces.

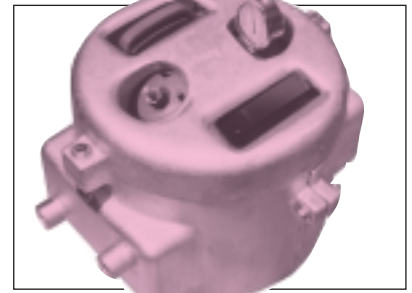

Pulsation Dampeners with ControHeat Jackets in high-temperature applications provide critical service for downstream instruments and meters. The jacket keeps the stagnant process fluid under the dampener's gas pad molten.

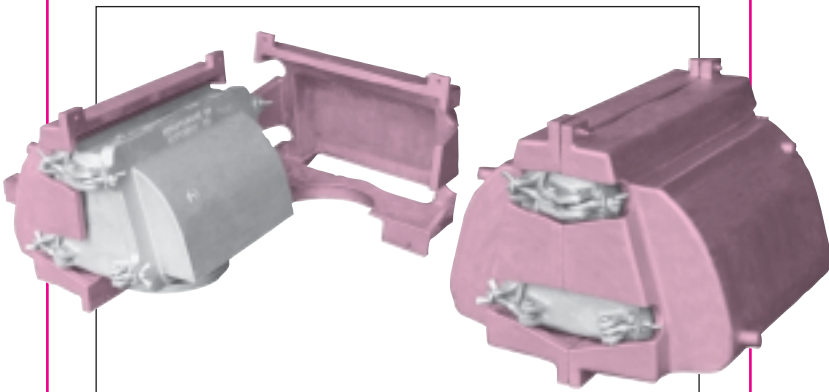

Condensables in gas streams can collect and choke the flow in flame arrestor passages. ControHeat Jackets keep the passages clear.

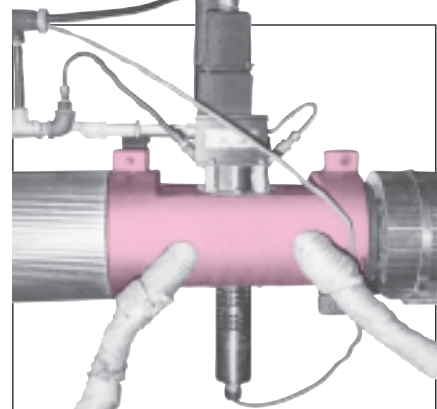

ControHeat Jacket on a Brookfield Viscometer increases the instrument's operating range and longevity, as well as improving accuracy of data collected.

ControTrace Elements Heat Pipe

ControTrace Heating Elements have performed very well in diverse applications from chocolate to polyester resin. Numerous plants have drastically curtailed their use of jacketed pipe, preferring to use ControTrace on process piping for DMT, rosins, sulfur, cyanuric chloride, acrylic acid, hot melts and numerous bottoms recirculating lines. Some of these plants fabricate the elements in the field. Others depend on CSI for the complete service of design, fabrication and installation of the bolt-on heating system.

ControTrace Elements are formed from carbon steel, SA178 Gr. A boiler tubing. The elements are pressure rated in accordance with the ASME Boiler and Pressure Vessel Code, Section VIII, Div.1.

The most popular size of ControTrace is a 1"x 2" rectangular

shape with the pipe-side surface formed to match the outside diameter of the pipe on which it will be placed. Normally, a non-drying heat-transfer cement is used to promote heat transfer between the element and the pipe wall.

For nominal pipe sizes of 1 1/2" and less, a smaller size of ControTrace (3/4"x1 1/2") is available. Other element sizes may be ordered on a

custom basis. Stainless steel ControTrace is also offered for very aggressive environments.

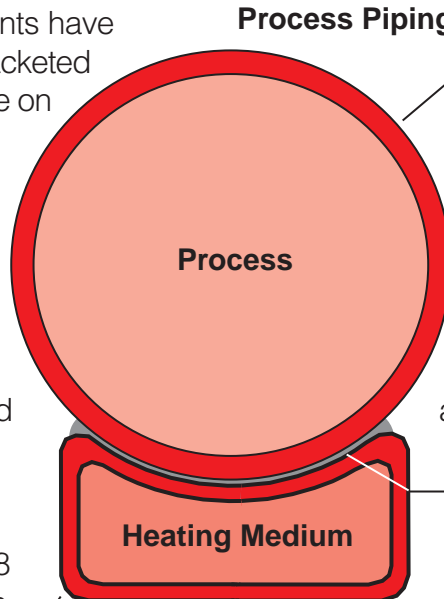

Custom Fabrication Options: Customers may opt for one of three methods to use when installing a heated piping system that utilizes ControTrace Elements.

1. CSI can turnkey the complete heated piping system. CSI provides the front-end engineering and drawings, fabricates the pipe and ControTrace (securing the ControTrace on the pipe), and installs the system in your plant. Another frequently used option is production by CSI of both the piping and ControTrace Elements, installing the elements on the pipe, insulating the finished assemblies, and shipping the system to the field for installation by others. We have the flexibility, of course, to provide only specified portions of the project.

2. Based on isometric drawings provided by the customer, CSI spools the elements and, with the customer's approval, fabricates finished ControTrace pieces, tests them, and ships them to the field, ready for installation on the pipe by others.

3. CSI provides individual components that owners use to fabricate on site their own bolt-on heating systems.

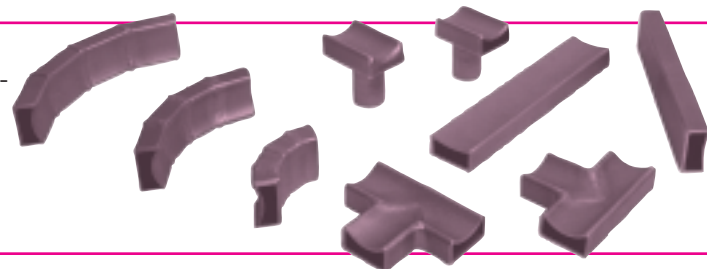
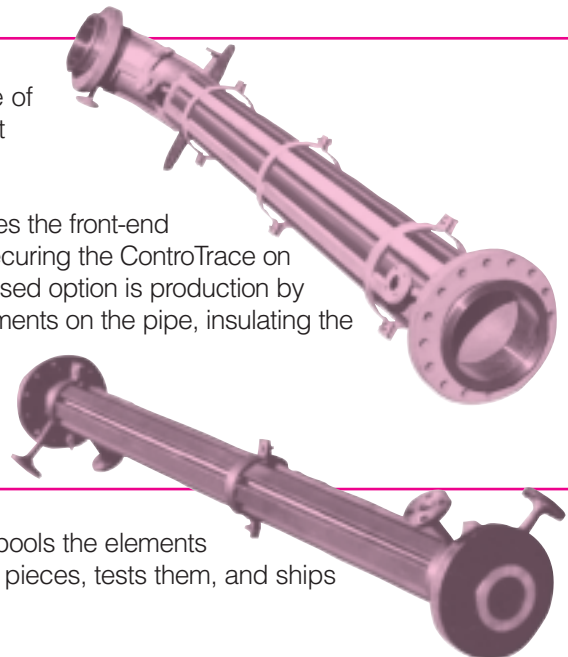

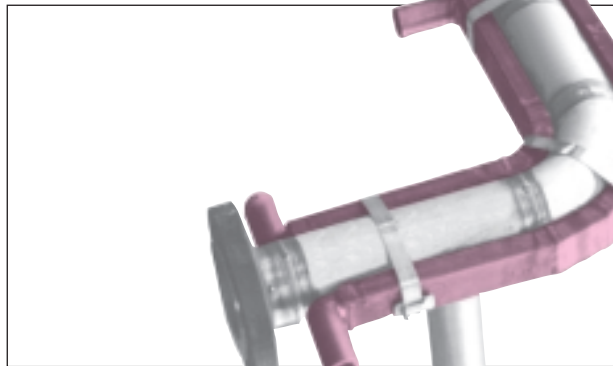

ControTrace coverage of elbows, even in smaller pipe diameters, as shown here, can be accomplished on both the throat and the heel. Side coverage of elbows also is frequently used.

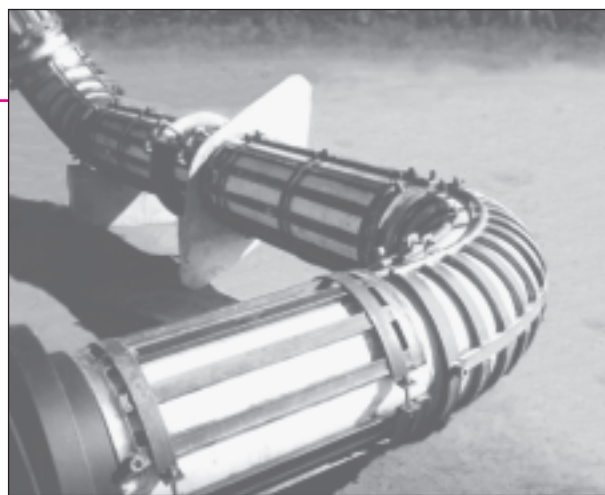

In the application depicted in the accompanying photo, ControTrace Elements proved to be a cost saving alternative to all-stainless steel jacketed pipe. With no external pressure, core piping was selected based on internal process requirements. This allowed a thinner pipe wall and saved money.

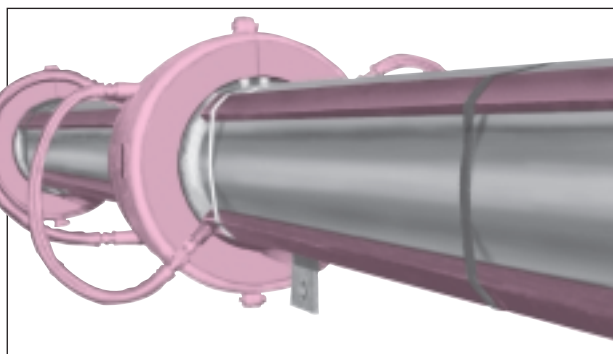

ControTrace is used successfully on piping in refineries, terminals, barges and acid plants. Combined with ControHeat jackets, as on the ball joints in this application, uniform heat can be provided to the the entire system very economically.

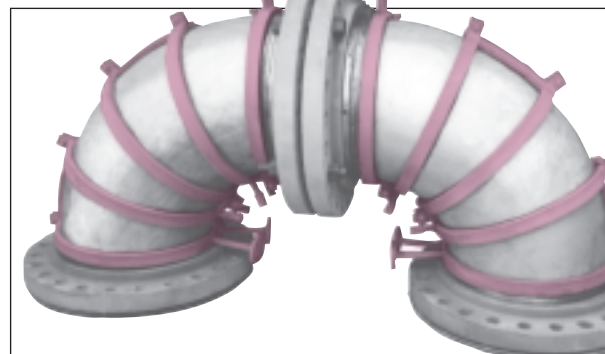

The design of the ControTrace coverage on a particular piping run depends on the process thermal requirements, pipe schedules, and the type and thickness of insulation used. In this application CSI designers determined that heating elements placed normal to the process flow would provide the most uniform coverage.

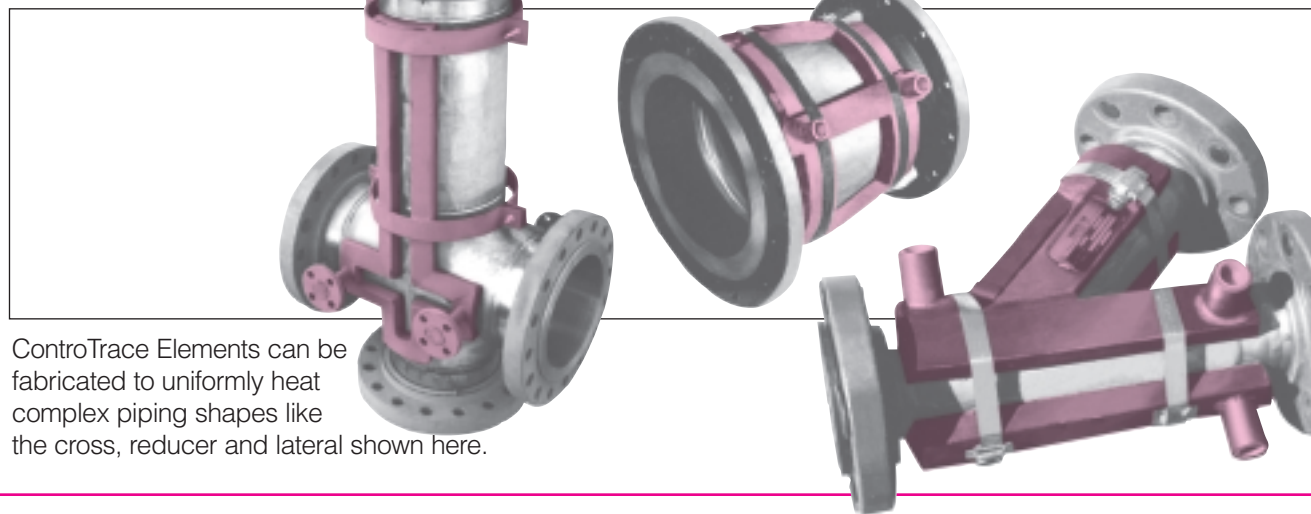

ControTrace Elements can be fabricated to uniformly heat complex piping shapes like the cross, reducer and lateral shown here.

ControTrace Heating Elements for Tanks & Vessels

Storage tanks and vessels up to 25 feet in diameter are in service with ControTrace elements providing uniform heat over their entire surfaces.

The ControTrace Element configuration can be designed for liquid or vapor heating media. A key benefit of ControTrace is that elements can be dispersed evenly around the vessel, assuring the uniform heat coverage. Jackets can be



fabricated for conic heads as well as elliptical heads. Generally, systems that utilize a liquid heating medium are designed in a serpentine configuration. Systems that use a vapor heating medium are usually constructed for parallel medium flow. When parallel flow must be used on a liquid system, flow diverters can be placed inside the ControTrace assemblies to channel the liquid.

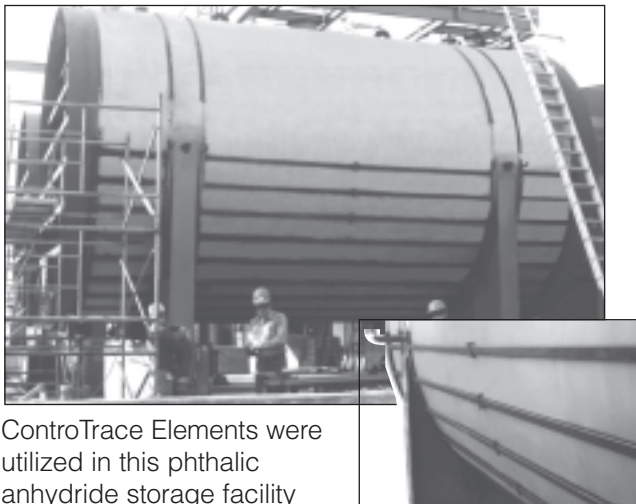

ControTrace Elements were utilized in this phthalic anhydride storage facility because the product could provide economical, uniform temperature maintenance in critical service.

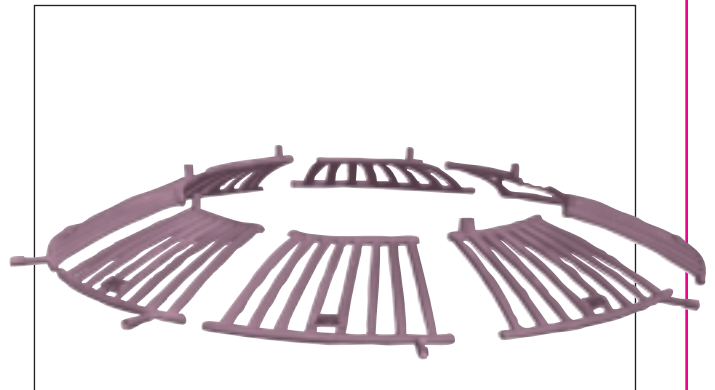

CSI has developed special fabrication techniques to achieve uniform heat coverage of vessel heads, allowing for various sizes of nozzle penetrations.



When liquid heating media are used, jacket elements are fabricated in a serpentine design to provide even heat distribution. Where non-condensables may cause vapor locks, bleed vents are added at strategic jacket locations.

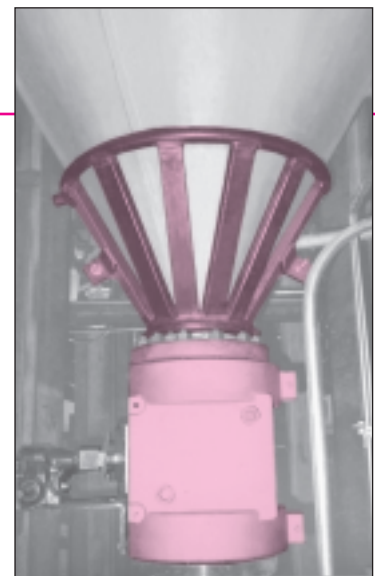

Conical vessel bottom with ControTrace.

Engineering Support for Bolt-On Heating Systems

A major segment of CSI's total business is the design and fabrication of jacketed piping systems. The continuing evolution of CSI Bolt-On Heating Systems is linked directly to the knowledge and experience we gain in jacketed piping, because the same



engineers and designers who manage jacketed piping projects also design and manage projects for bolt-on heating systems. The singular focus of this cumulative experience, from initial quotations through process start-up, is a satisfied customer that likes doing business with CSI.

Two Computer Tools

1. To assist customers in determining the right amount of bolt-on heat coverage, CSI has developed a computer program that allows inputs of up to five process variables. These variables are type and thickness of insulation, process temperature, heating medium temperature, ambient design temperature, and nominal pipe or tank sizes. Several values may be selected for each variable. The data produced from these variables is used to determine the optimum system. Results of the program tell designers the number of ControTrace Elements to be used, the energy loss per hour per foot of pipe and the consumption of heating fluid used per hour per foot of pipe.



2. The second computer program, more sophisticated than the first, uses finite difference modeling to profile the crosssectional thermal performance of the bolt-on heating system. The results yield a detailed temperature profile of the piping system at equilibrium, the heat lost to the atmosphere through the insulation, and the net heat input to the process. This program considers the thermal conductivities of the system components as well as film coefficients of both the process and the heating fluid.

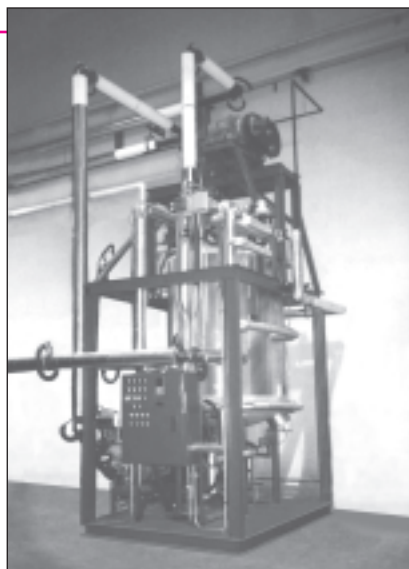
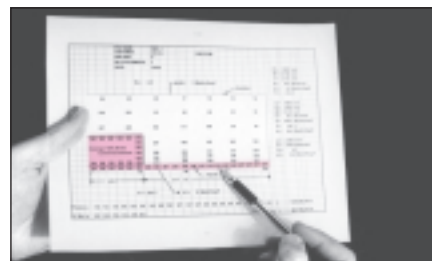

Hot Melt reactor with ControTrace elements on vessel and ControHeat Jackets on valves, pumps and instruments.



CSI-designed Bolt-on Heating System installed in Sulfur Recovery Unit of a large gas plant. Run-down and distribution piping utilize ControTrace Elements. Fittings are heated with ControHeat Jackets.

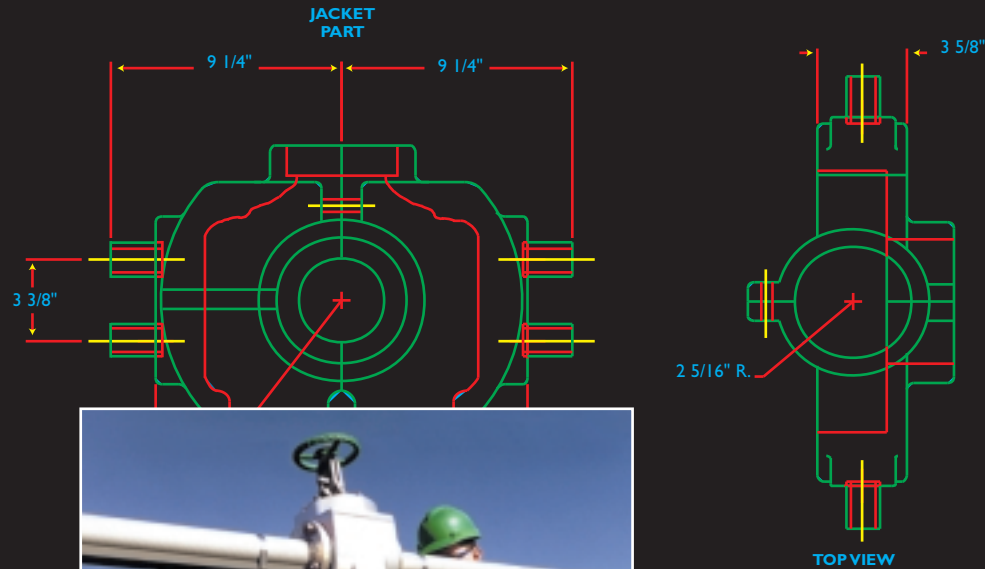

ControTrace elements on this rail car solved a critical maintenance problem for a major producer of caprolactam.

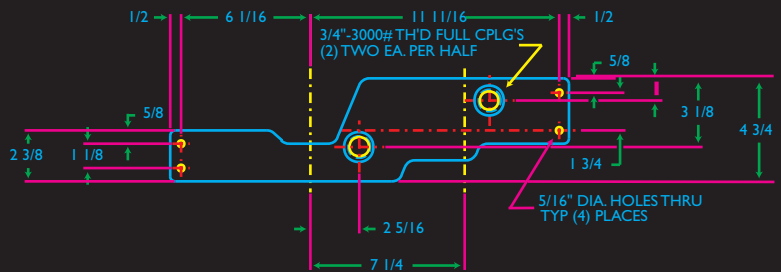
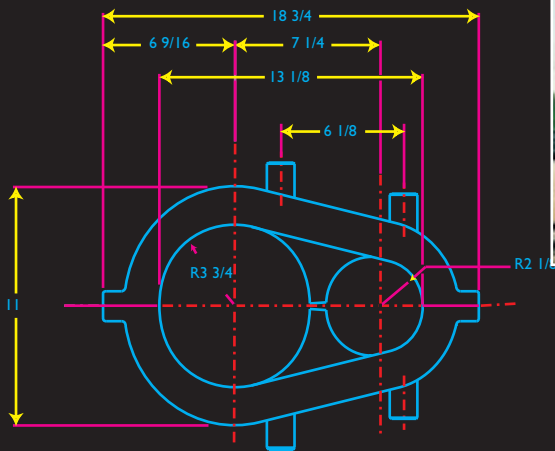

For additional information and quotations, please write or call:



Controls Southeast, Inc.
 P.O. Box 7500
 Charlotte, NC 28241
 Phone: (704) 588-3030
 Fax: (704) 588-3039
 web: www.csiheat.com
 e-mail: sales@csiheat.com



CSI Headquarters, Charlotte, North Carolina